

## Product Description

The 802.11 a/b/g/n direct conversion transceiver IP core supports OFDM, WLAN and ISM applications. Covering both the 2.4-2.5GHz band and extended world band frequencies 4.9GHz-5.875GHz, the IQ architecture integrates all of the required radio functions incorporating the complete Rx, Tx and synthesizer and data converter subsystems in a 130nm RF CMOS IP core.

An integrated FRAC-N synthesizer can be configured for a wide range of low cost crystal frequencies from 20MHz-40MHz and provides a reference clock output for ease of integration in System On Chip (SoC) applications.

A Flexible Radio Control Interface can be optimized for embedded SoC applications.

## Typical Applications

- 802.11 a/b/g/n standards for WiFi
- ISM band applications for M2M and wireless data
- NxN MIMO configurations for high data throughput

## Features

Fully Integrated 802.11 a/b/g/n Transceiver

- Rx Chain with AGC and RSSI
- Fully integrated FRAC N Synthesizer
- Integrated Loop Filter
- Low Jitter Programmable Clock PLL
- Tx Chain with 0dBm linear output power
- DC offset calibration and envelope detection circuits

High Performance

- 3dB Noise Figure at Max Gain
- -10dBm out of band IIP3
- 92dB Rx Digital Gain control
- Programmable Filter Bandwidths for 7.5MHz,9.5MHz,14MHz ,20MHz and 40 MHz modes

Low Power Consumption

- 1.5V supply
- Rx mode 90mA with boost mode to 130mA
- Tx mode 100mA with boost mode to 140mA

## Functional Block Diagram

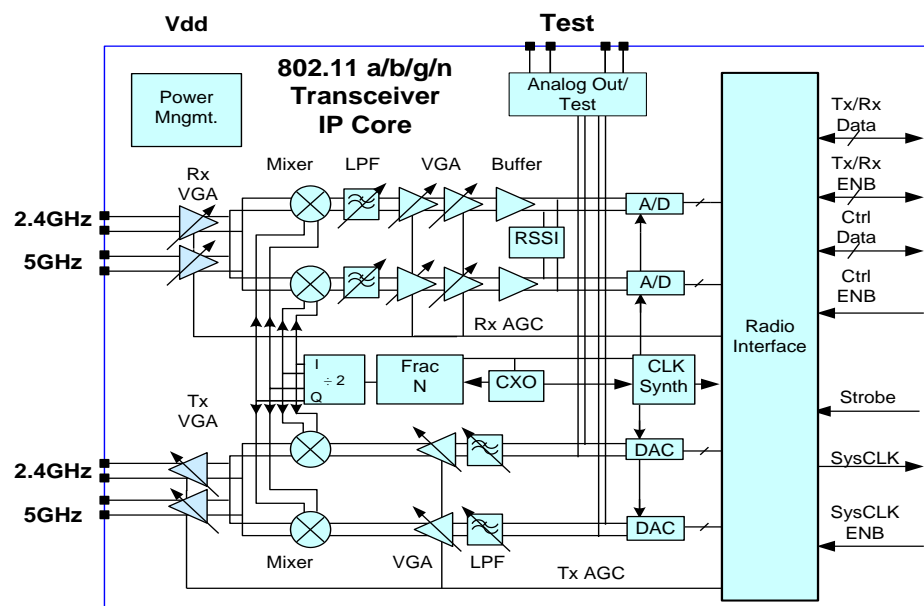

## Specifications

Parameter	Conditions	Units	Min	Typ	Max
RF Frequency Range Low band		MHz	2405		2480
RF Frequency Range High band		MHz	4900		5900
Rx Maximum Voltage Gain		dB		95	
Rx Gain Control Range	Monotonic	dB		92	
Rx Gain Flatness	+/-40MHz	dB		+/-0.5	
Low band Noise Figure at Max Gain		dB		3.0	
High band Noise Figure at Max Gain		dB		4.0	
Rx I/Q mismatch		dB		-40	
DC Offset	Calibrated	mV		+/-10mV	
Adjacent Channel Rejection	20MHz mode at 20MHz offset	dB		20	
Baseband 3dB corner	20MHz mode	MHz		9	
Ultimate Rejection	20MHz mode	dB		45	
RSSI dynamic range	RMS power detection	dB		60	
Input Impedance	Single Ended or Differential	Ohms		50/100	
Tx Output Power Max gain		dBm		0	
Tx EVM		%		1.5	
Tx Harmonics		dB		-45	
Tx Gain Flatness	+/-20MHz	dB		+/-0.5	
Tx Power control range		dB		30	
IQ Mismatch	Post Calibration over temp and voltage	dB		-40	
Low band Output Noise Power	20MHz mode and +/-22MHz 0dBm out	dBm/MHz		-66	
High band Output Noise Power	20MHz mode and +/-32MHz 0dBm out	dBm/MHz		-66	
Output Impedance	Single Ended or Differential			50/100	
Crystal Reference Oscillator		MHz	20		40
Low band Center Frequency Spacing		MHz		1	
Low band Center Frequency Spacing		MHz		5	
Integrated Phase Noise	10kHz to 10MHz	Degrees		0.6	
Spur level		dBc		-65	
VCO Settling time	1kHz of final value	us		50	
Rx/Tx turn around time		us		1	
Supply Voltage		V		1.5	
Rx Mode Current	Nominal Mode	mA		90	
Tx Mode Current	Nominal Mode	mA		100	
ADC Resolution		bits		12	
ADC Sample Rate		MSPS		80	
ADC SFDR		dB		70	
ADC SINAD	Fin=10MHz	dB		55	
DAC Resolution		bits		12	
Sample Rate		MSPS		200	
SFDR	45MHz output	dB		66	
SINAD	45MHz	dB		56	

### IP Status – Presilicon

This datasheet contains information from the design target specification. RF integration Inc. reserves the right to change information at any time without notification. Information furnished is provided on an "as is" basis. RF Integration Inc. assumes no responsibility or liability for the direct or indirect consequences of the use of such information nor for any infringement of patents or other rights of third parties, which may result from its use. No license or indemnity is granted by implication or otherwise under any patent or other intellectual property rights of RF Integration Inc. or third parties.

RF Integration Inc., 85 Rangeway Rd. Bld#1 Billerica, MA01862. USA Tel: (978)-654-6770 E mail: sales@rfintegration.com <a href="http://www.rfintegration.com">www.rfintegration.com</a>
---