

## Product Description

The software definable GNSS core enables simultaneous reception of all commercial GNSS signals in the 1560-1610MHz frequency range. It contains all the RF, IF, analog, data converter and power management circuitry for a complete GNSS core in a low cost CMOS 180nm process. The core includes clock generation circuitry for a configurable 2/3 bit quadrature converter which also provides a low jitter clock source for SoC applications. The configurable core can receive the traditional GPS L1 frequencies as well as the GLONASS G1, Galileo E1 and Compass B1-1 and B1-2 bands. A configurable bandpass filter and variable rate A/D converter allows each band to be received separately in single channel mode or all bands to be received together for high precision applications. The design employs a unique quadrature detection architecture for maximum flexibility.

An integrated FRAC-N synthesizer can be configured for a wide range of low cost cellular crystal frequencies from 10MHz-52MHz.

## Typical Applications

- Cellular Phones and Handheld Products
- Asset Tracking
- Precision Location and Positioning
- GNSS Timing Applications

## Features

### Single Channel Mode

- GPS L1 1575.42MHz
- GLONASS G1 1603.50MHz
- Galileo E1 1575.42MHz
- Compass B1-1 1561.098MHz
- Compass B1-2 1589.792MHz

### Block Conversion mode

- Variable sampling rate 8-80MHz
- Simultaneous conversion of all commercial GNSS signals

### Configurable 3/4 wire controller

### 2/3 bits A/D Quadrature detection

### Integrated AGC

- 50dB gain control range
- Programmable threshold

### Low Power

- Single 1.8V supply with internal regulation
- 18mA in Single Channel mode
- 29mA in Block Conversion

## Functional Block Diagram

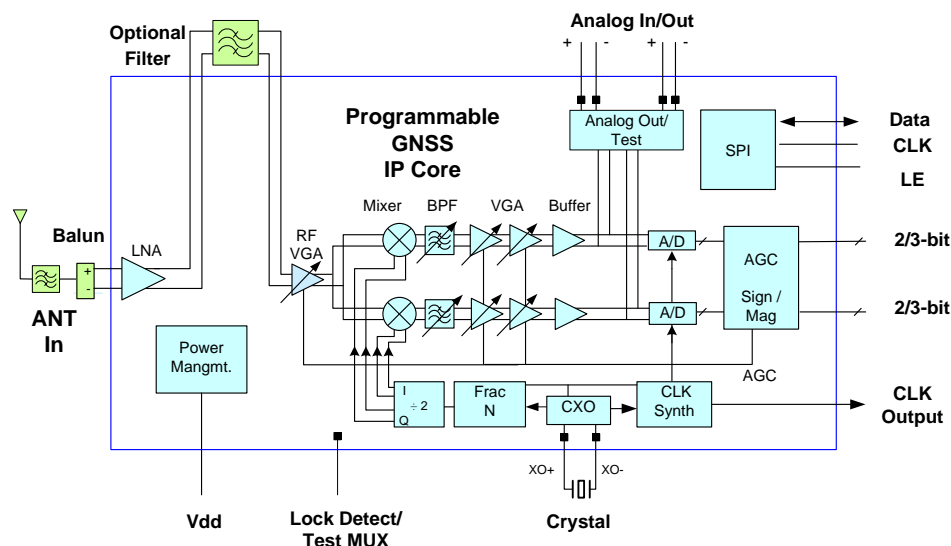

## GNSS Core Specifications

Parameter	Conditions	Units	Min	Typ	Max
RF Frequency Range		MHz	1560		1610
IF Frequency	Configured Via SPI Interface	MHz	4		50
Sampling Rate		MHz	8		80
Band Pass Filter Bandwidth	Configured Via SPI Interface	MHz	2		44
Max Gain	LNA Enabled			100	
Max Gain	Downconverter only	dB		80	
Gain control range		dB		50	
Step size		dB		0.25	
Noise Figure	LNA Enabled	dB		2	
Noise Figure	Downconverter only	dB		10	
SSB Phase Noise	At 1kHz offset for 1.6GHz LO	dBc/Hz		-94	
SSB Phase Noise	At 10kHz offset for 1.6GHz LO	dBc/Hz		-102	
SSB Phase Noise	At 100kHz offset for 1.6GHz LO	dBc/Hz		-101	
SSB Phase Noise	At 1MHz offset for 1.6GHz LO	dBc/Hz		-124	
RMS phase error	1.5GHz LO frequency	degrees		3	
RMS Clock Jitter		ps		3	
Current	Vdd 1.8V Block conversion mode	mA		29	
Current	Vdd 1.8V Single Channel mode	mA		18	
Reference Frequency		MHz	10		52
A/D converter resolution	Configured Via SPI Interface			2/3	

### IP Status - Presilicon

### Preliminary Information

This datasheet contains information from the design target specification. RF integration Inc. reserves the right to change information at any time without notification.

Information furnished is believed to be accurate and reliable and is provided on an “as is” basis. RF Integration Inc. assumes no responsibility or liability for the direct or indirect consequences of the use of such information nor for any infringement of patents or other rights of third parties, which may result from its use. No license or indemnity is granted by implication or otherwise under any patent or other intellectual property rights of RF Integration Inc. or third parties. Specifications mentioned in this publication are subject to change without notice. This publication supersedes and replaces all information previously supplied.

### Contact Information

RF Integration Inc.,  
85 Rangeway Rd. Blid#1  
Billerica, MA01862.  
USA

Tel: (978)-654-6770

Fax: (978)-654-6772

E mail: [sales@rfintegration.com](mailto:sales@rfintegration.com)

[www.rfintegration.com](http://www.rfintegration.com)